

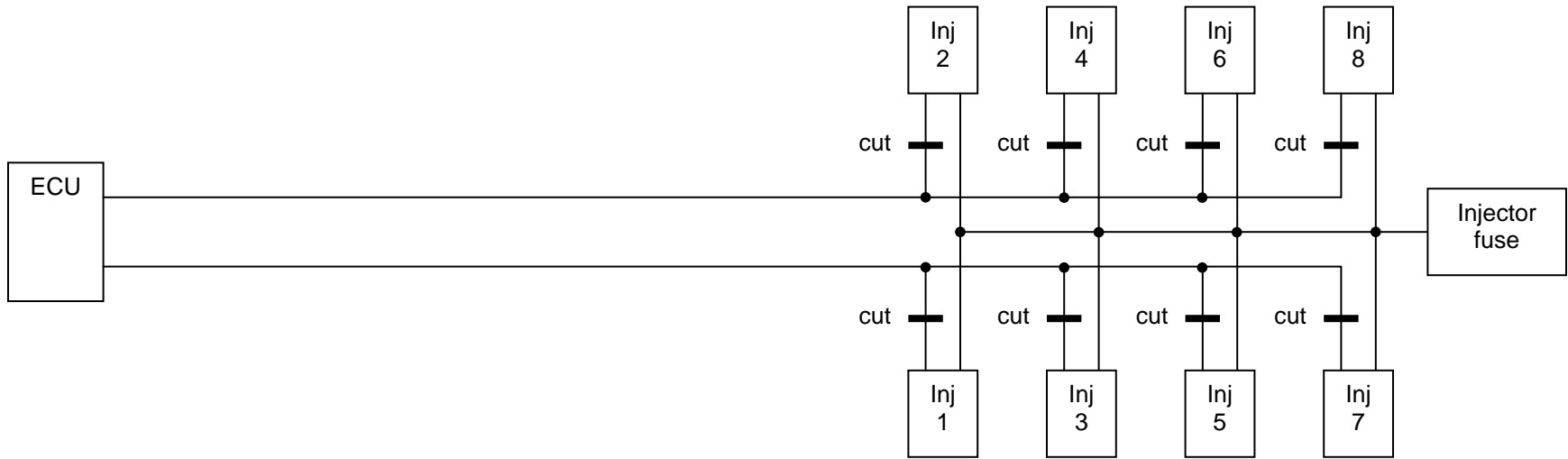

VersaFueler™ Model 2 Bank Fire Injection Wiring Diagram

Step 1, cut the 8 injector control wires (these are the wires going from the ECU to the injectors – see the Emergency Backup Instructions).



Step 2, identify the injector wire stubs (1a, 2a, 3a, etc, in the figure below) and the ECU stubs (1b, 2b, 3b, etc, in the figure below).

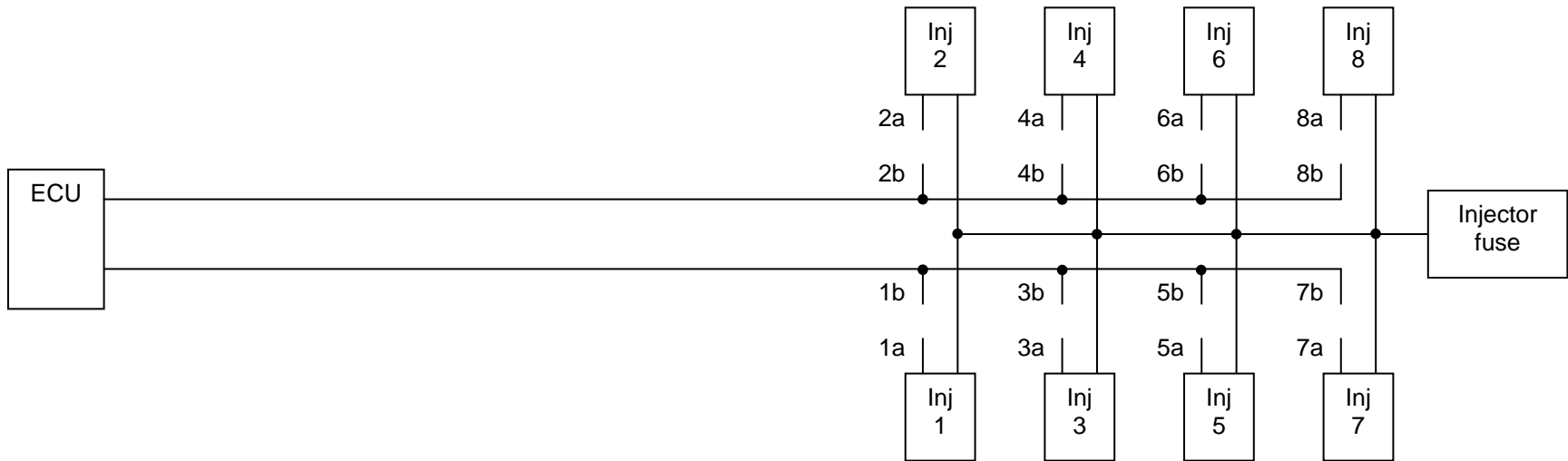



VersaFueler™ Model 2 Bank Fire Injection Wiring Diagram

Step 3, Splice injector wire stubs to VersaFueler™ outputs and ECU wire stubs to VersaFueler™ inputs using the supplied crimp connectors.

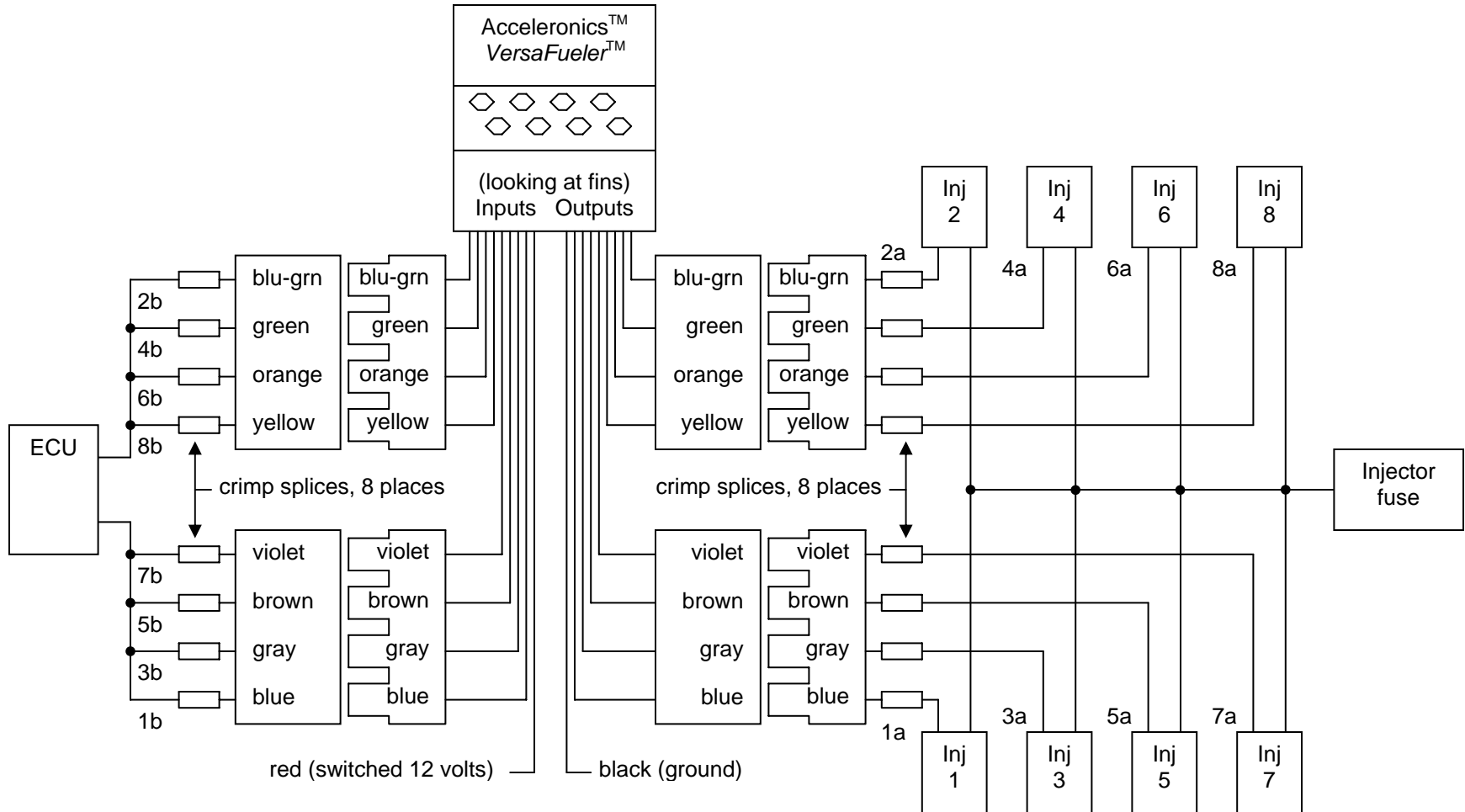

Step 4, attach the black wire ring terminal to a clean, shiny ground such as an engine or chassis bolt.

Step 5, splice the red wire to a source of switched 12 volt power such as the wire from the injector fuse to the injectors.

Step 6, there is no Step 6, you're done!